

## QL-R Series Linear Positioning Stage

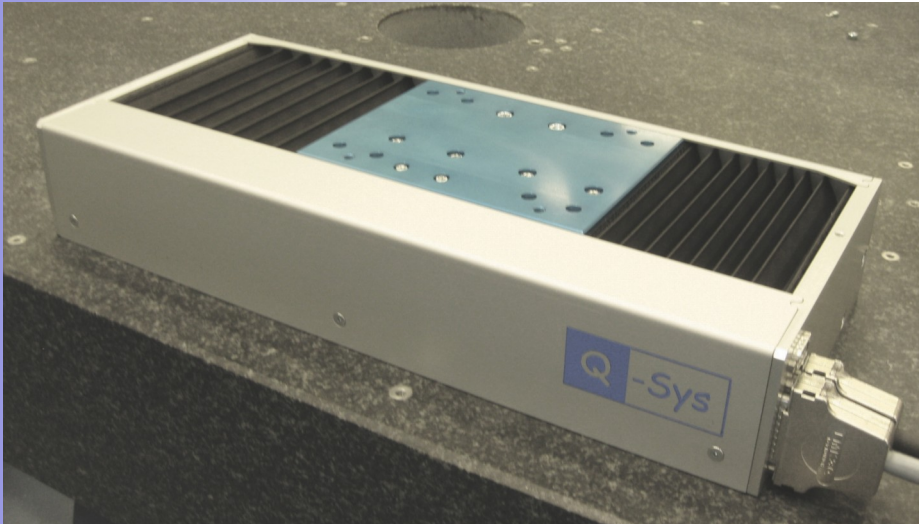

- Compact, stiff design
- Linear motor driven
- Optical position feedback
- Recirculating ball bearings
- Internal cable management
- High reliability
- Travels from 150 to 1500mm

With a proven design and using the highest quality components, Q-Sys QL-R stages are perfectly suited to demanding applications requiring high speeds and accelerations while maintaining positional accuracy. The combination of linear motor drive, non-contact optical encoder and robust recirculating ball bearings produces a stage with excellent dynamic performance, high precision and long service life with minimal maintenance needs.

Shown here in single axis form, the stages are also suitable for XY mounting to within 10 arcseconds to produce a highly cost effective 2D system.



# Specifications

Travel	150 to 1500 mm
Accuracy <sup>1</sup>	±8 microns per 300mm
Encoder resolution	From 5 microns down to 0.1 micron or better
Repeatability <sup>2</sup>	±1 micron with resolution 0.5 micron or better
Straightness/ Flatness	±5 micron + 10 microns per 300mm
Roll, pitch, yaw	±10 arcs + 8 arcs per 300mm
Load capacity	30kg
Velocity and acceleration	Up to 4m/sec and 4g depending on motor and load
Dimensions	See below – overall length depends on travel

1. Including repeatability

2. With no load and measured 50mm above carriage

**Note:** Q-Sys offers an extensive range of alternatives designs. For extended travels, non-standard configurations or any other requirements, please contact us.

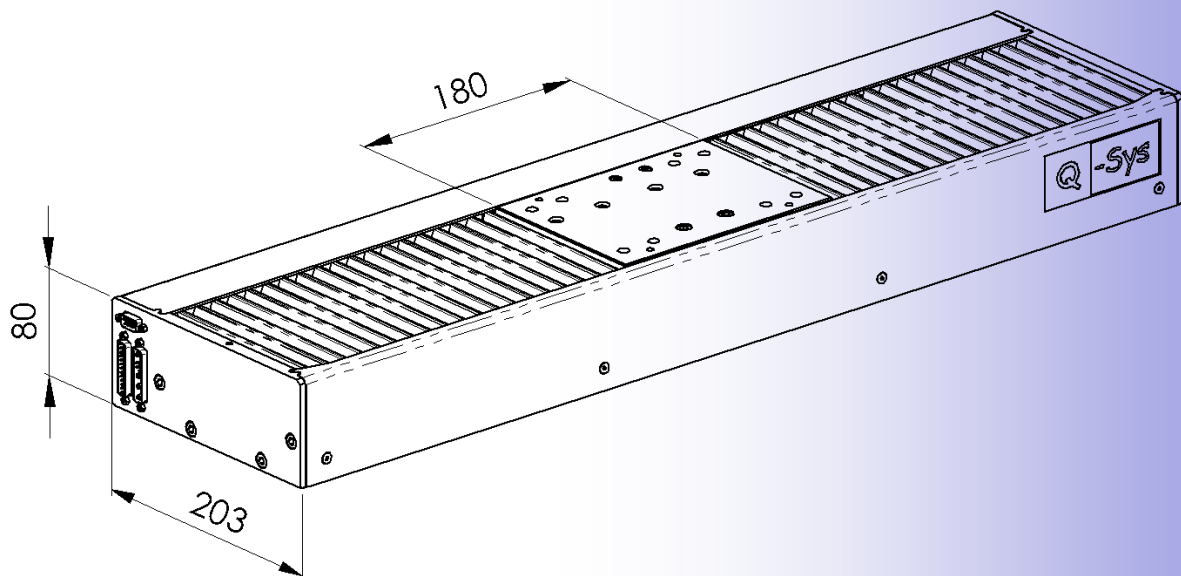

## Q-Sys BV

Korte Dijk 2  
5705 CV Helmond  
The Netherlands

Tel: +31 (0)492 714434  
Fax: +31 (0)492 714435  
Email: sales@q-sys.eu

## Q-Sys UK

Wakeswood Lodge  
St Mary Bourne  
Andover SP11 6EW  
England

Tel: +44 (0)1264 848245  
Mob: +44 (0)7810 124425  
Email : sales@q-sys.eu